

**Silicon PIN Diode**

- Current-controlled RF resistor for RF attenuators
- Frequency range 1 MHz ... 2 GHz
- Especially useful as antenna switch in TV-sat tuners

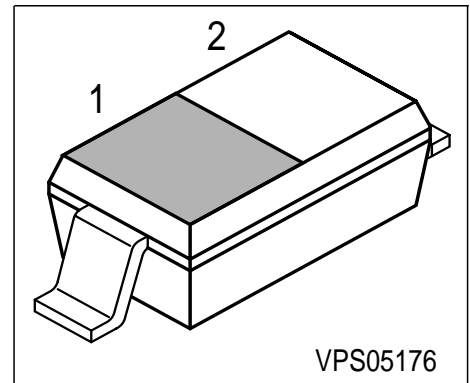

Type	Marking	Pin Configuration		Package
BA595	white R	1 = C	2 = A	SOD323

**Maximum Ratings**

Parameter	Symbol	Value	Unit
Diode reverse voltage	$V_R$	50	V
Forward current	$I_F$	50	mA
Operating temperature range	$T_{op}$	-55 ... 125	°C
Storage temperature	$T_{stg}$	-55 ... 150	

**Thermal Resistance**

Junction - soldering point <sup>1)</sup>	$R_{thJS}$	≤ 370	K/W
--	------------	-------	-----

<sup>1)</sup>For calculation of  $R_{thJA}$  please refer to Application Note Thermal Resistance

**Electrical Characteristics** at  $T_A = 25^\circ\text{C}$ , unless otherwise specified.

Parameter	Symbol	Values			Unit
		min.	typ.	max.	
<b>DC characteristics</b>					
Reverse current $V_R = 30\text{ V}$	$I_R$	-	-	20	nA
Forward voltage $I_F = 50\text{ mA}$	$V_F$	-	-	1.1	V
<b>AC Characteristics</b>					
Diode capacitance $V_R = 0\text{ V}, f = 100\text{ MHz}$ $V_R = 10\text{ V}, f = 1\text{ MHz}$	$C_T$	-	0.26 0.22	0.6 0.4	pF
Forward resistance $I_F = 1.5\text{ mA}, f = 100\text{ MHz}$ $I_F = 10\text{ mA}, f = 100\text{ MHz}$	$r_f$	-	21 4.5	40 7	$\Omega$
Reverse resistance $V_R = 1\text{ V}, f = 100\text{ MHz}$	$1/g_p$	-	50	-	k $\Omega$
Charge carrier life time $I_F = 10\text{ mA}, I_R = 6\text{ mA}, I_R = 3\text{ mA}$	$\tau_{rr}$	-	1.6	-	$\mu\text{s}$
Series inductance	$L_s$	-	1.8	-	nH

**Diode capacitance  $C_T = f(V_R)$**

$f = 1\text{MHz}$

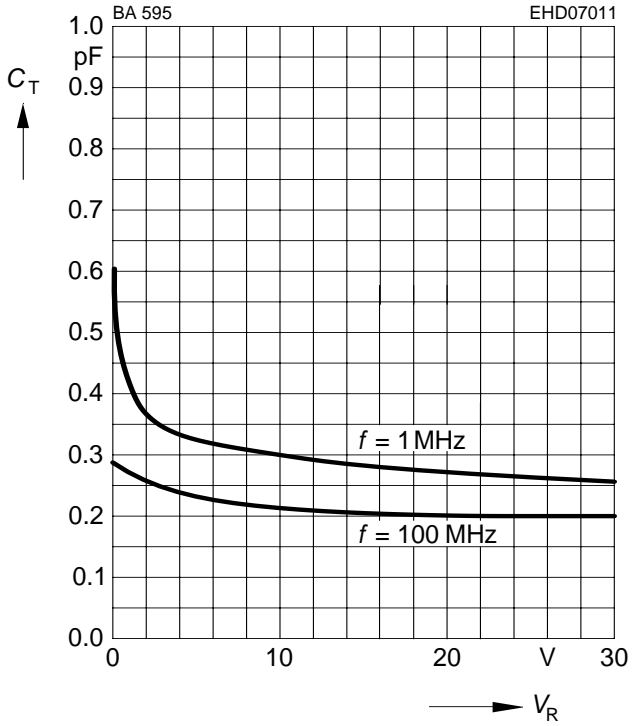

**Forward resistance  $r_f = f(I_F)$**

$f = 100\text{MHz}$

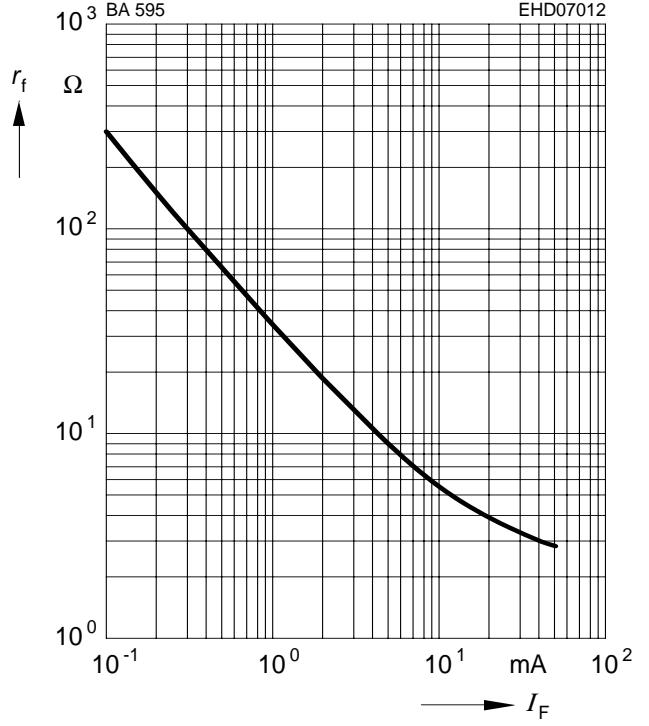

**Forward current  $I_F = f(T_S)$**

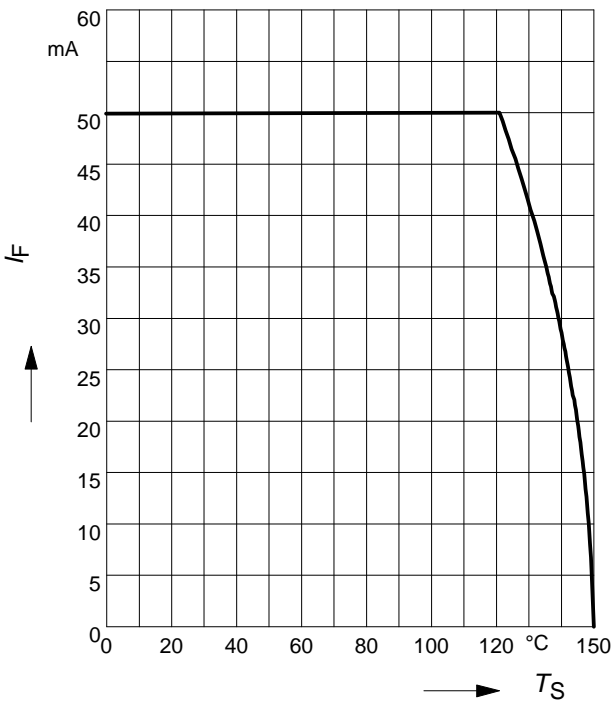

Permissible Pulse Load  $R_{thJS} = f(t_p)$

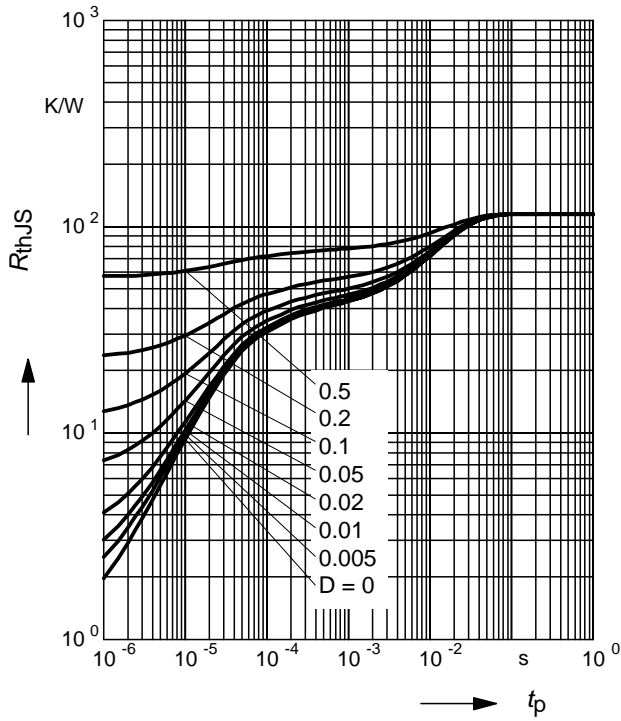

Permissible Pulse Load

$I_{Fmax} / I_{FDC} = f(t_p)$

