

FEATURES

- **VERY LOW NOISE FIGURE:**
0.8 dB typical at 12 GHz
- **HIGH ASSOCIATED GAIN:**
10.5 dB Typical at 12 GHz
- **GATE LENGTH:** 0.3 μm
- **GATE WIDTH:** 280 μm
- **LOW COST METAL/CERAMIC PACKAGE**
- **TAPE & REEL PACKAGING OPTION AVAILABLE**

DESCRIPTION

The NE33284A is a Hetero-Junction FET that uses the junction between Si-doped AlGaAs and undoped InGaAs to create very high mobility electrons. The device features mushroom shaped TiAl gates for decreased gate resistance and improved power handling capabilities. The mushroom gate also results in lower noise figure and high associated gain. This device is housed in an epoxy-sealed, metal/ceramic package and is intended for high volume consumer and industrial applications.

NOISE FIGURE & ASSOCIATED GAIN vs. FREQUENCY
 $V_{DS} = 2.0 \text{ V}, I_{DS} = 10 \text{ mA}$

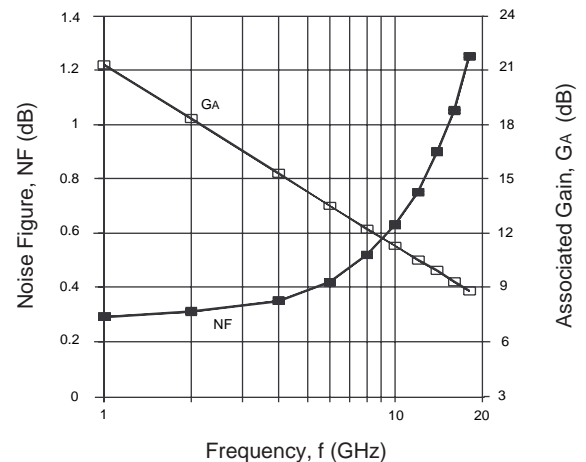

ELECTRICAL CHARACTERISTICS ($T_A = 25^\circ\text{C}$)

PART NUMBER PACKAGE OUTLINE			NE33284A 84AS		
SYMBOLS	PARAMETERS AND CONDITIONS	UNITS	MIN	TYP	MAX
NF_{OPT}^1	Optimum Noise Figure, $V_{DS} = 2.0 \text{ V}, I_{DS} = 10 \text{ mA}, f = 12 \text{ GHz}$ $f = 4 \text{ GHz}$	dB dB		0.75 0.35	1.0 0.45
GA^1	Associated Gain, $V_{DS} = 2.0 \text{ V}, I_{DS} = 10 \text{ mA}, f = 12 \text{ GHz}$ $f = 4 \text{ GHz}$	dB dB	9.5 13.0	10.5 15.0	
P_{1dB}	Output Power at 1 dB Gain Compression Point, $f = 12 \text{ GHz}$ $V_{DS} = 2.0 \text{ V}, I_{DS} = 10 \text{ mA}$ $V_{DS} = 2.0 \text{ V}, I_{DS} = 20 \text{ mA}$	dBm dBm		11.2 12.0	
G_{1dB}	Gain at $P_{1dB}, f = 12 \text{ GHz}$ $V_{DS} = 2.0 \text{ V}, I_{DS} = 10 \text{ mA}$ $V_{DS} = 2.0 \text{ V}, I_{DS} = 20 \text{ mA}$	dB dB		10.8 11.0	
I_{DSS}	Saturated Drain Current, $V_{DS} = 2.0 \text{ V}, V_{GS} = 0 \text{ V}$	mA	15	40	80
V_P	Pinch-off Voltage, $V_{DS} = 2.0 \text{ V}, I_{DS} = 0.1 \text{ mA}$	V	-2.0	-0.8	-0.2
g_m	Transconductance, $V_{DS} = 2.0 \text{ V}, I_D = 10 \text{ mA}$	mS	45	70	
I_{GSO}	Gate to Source Leakage Current, $V_{GS} = -3.0 \text{ V}$	μA		0.5	10.0
$R_{TH}(CH-A)$	Thermal Resistance (Channel to Ambient)	$^\circ\text{C/W}$		630	
$R_{TH}(CH-C)^2$	Thermal Resistance (Channel to Case)	$^\circ\text{C/W}$		280	310

Notes:

1. Typical values of noise figures and associated gain are those obtained when 50% of the devices from a large number of lots were individually measured in a circuit with the input individually tuned to obtain the minimum value. Maximum values are criteria established on the production line as a "go-no-go" screening tuned for the "generic" type but not for each specimen.
2. R_{TH} (channel to case) for package mounted on an infinite heat sink.

ABSOLUTE MAXIMUM RATINGS¹ (T_A = 25°C)

SYMBOLS	PARAMETERS	UNITS	RATINGS
V _{DS}	Drain to Source Voltage	V	4.0
V _{GS}	Gate to Source Voltage	V	-3.0
I _{DS}	Drain Current	mA	I _{DSS}
I _{GRF}	Gate Current	μA	280
P _{IN}	RF Input (CW)	dBm	15
T _{CH}	Channel Temperature	°C	150
T _{STG}	Storage Temperature	°C	-65 to +150
P _T	Total Power Dissipation	mW	165

Note:
1. Operation in excess of any one of these conditions may result in permanent damage.

TYPICAL NOISE PARAMETERS (T_A = 25°C)

V_{DS} = 2 V, I_{DS} = 10 mA

FREQ. (GHz)	NF _{OPT} (dB)	G _A (dB)	Γ _{OPT}		Rn/50
			MAG	ANG	
1	0.29	21.3	0.85	28	0.48
2	0.31	18.3	0.82	40	0.27
4	0.35	15.0	0.74	62	0.16
6	0.42	13.5	0.67	85	0.13
8	0.52	12.2	0.59	107	0.10
10	0.63	11.3	0.52	130	0.09
12	0.75	10.5	0.45	168	0.10
14	0.90	9.9	0.37	-146	0.14
16	1.05	9.3	0.30	-100	0.22
18	1.25	8.8	0.22	-54	0.34

TYPICAL PERFORMANCE CURVES (T_A = 25°C)

TOTAL POWER DISSIPATION vs. AMBIENT TEMPERATURE

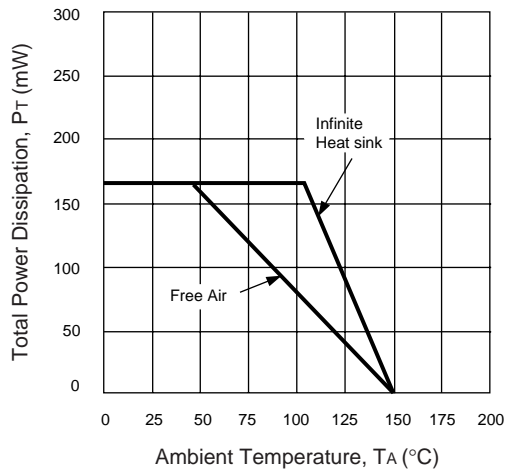

TRANSCONDUCTANCE vs. DRAIN CURRENT
V_{DS} = 2.0 V

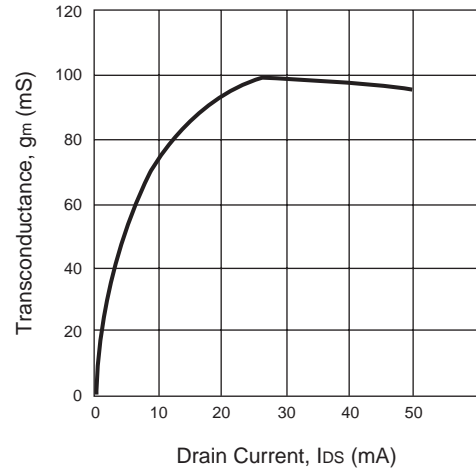

DRAIN CURRENT vs. DRAIN TO SOURCE VOLTAGE

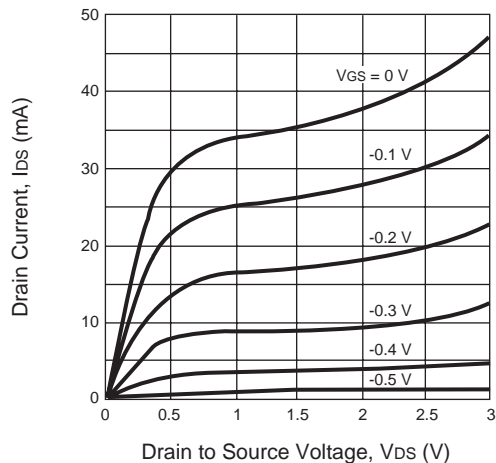

NOISE FIGURE AND GAIN vs. DRAIN CURRENT
V_{DS} = 2 V, f = 12 GHz

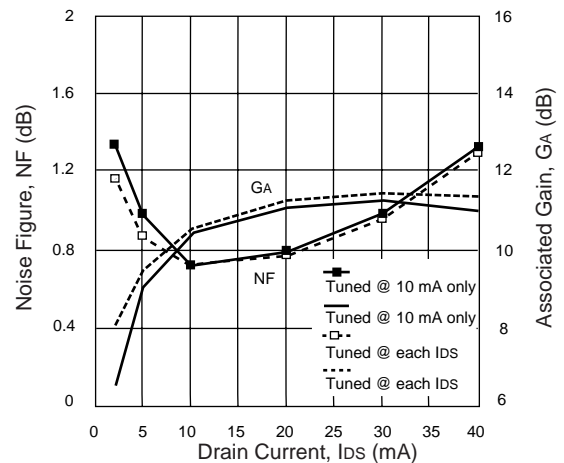

TYPICAL COMMON SOURCE SCATTERING PARAMETERS (T_A = 25°C)

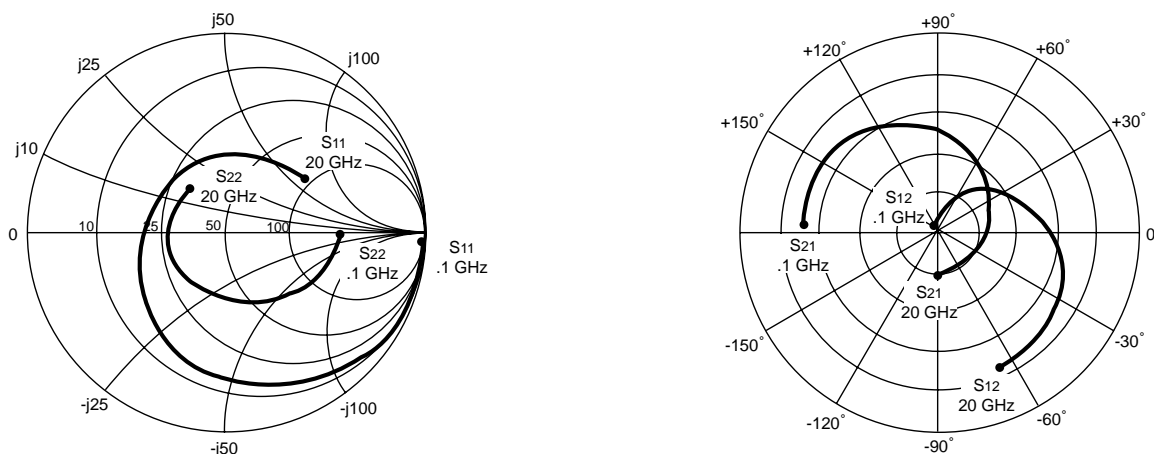

V_{DS} = 2 v, I_{DS} = 10 mA

FREQUENCY (GHz)	S ₁₁		S ₂₁		S ₁₂		S ₂₂		K	S ₂₁ (dB)	MAG ¹ (dB)
	MAG	ANG	MAG	ANG	MAG	ANG	MAG	ANG			
0.1	.999	-1.7	5.712	178.3	.002	89.2	.630	-1.2	0.05	15.1	34.6
0.2	.999	-4.0	5.660	176.3	.004	88.9	.630	-2.8	0.02	15.1	31.5
0.5	.998	-10.4	5.660	170.2	.011	83.5	.632	-7.0	0.04	15.1	27.1
1.0	.981	-21.3	5.604	160.0	.022	76.3	.627	-13.9	0.14	15.0	24.1
2.0	.935	-41.3	5.414	141.1	.041	65.0	.599	-26.9	0.25	14.7	21.2
3.0	.876	-60.8	5.117	123.0	.056	54.2	.564	-39.1	0.36	14.2	19.6
4.0	.809	-78.1	4.732	106.6	.071	44.7	.534	-49.8	0.47	13.5	18.2
5.0	.738	-94.7	4.382	91.7	.080	36.4	.492	-60.2	0.59	12.8	17.4
6.0	.671	-110.7	4.058	77.6	.087	29.1	.455	-69.9	0.70	12.2	16.7
7.0	.619	-125.6	3.746	64.1	.094	22.6	.430	-79.5	0.79	11.5	16.0
8.0	.578	-139.1	3.491	52.2	.100	18.4	.416	-88.6	0.85	10.9	15.4
9.0	.542	-151.7	3.289	40.1	.106	13.6	.405	-97.2	0.90	10.3	14.9
10.0	.499	-164.8	3.130	28.3	.113	7.2	.394	-106.0	0.96	9.9	14.4
11.0	.455	-179.3	2.995	16.4	.121	3.1	.377	-114.7	1.00	9.5	13.7
12.0	.431	164.4	2.855	4.7	.126	-2.3	.361	-125.2	1.04	9.1	12.3
13.0	.425	148.0	2.752	-6.8	.133	-8.1	.340	-137.0	1.04	8.8	11.9
14.0	.417	133.1	2.664	-17.9	.139	-13.5	.332	-149.2	1.04	8.5	11.5
15.0	.402	116.8	2.579	-30.2	.149	-20.8	.336	-161.8	1.03	8.2	11.4
16.0	.393	98.3	2.515	-42.7	.155	-29.0	.334	-174.8	1.03	8.0	11.1
17.0	.396	78.7	2.430	-55.5	.163	-37.4	.337	171.2	1.01	7.7	11.0
18.0	.426	61.5	2.348	-68.3	.170	-45.7	.333	156.8	0.99	7.4	11.4
19.0	.462	49.2	2.281	-80.1	.173	-56.0	.328	139.7	0.96	7.2	11.2
20.0	.491	33.8	2.208	-93.7	.176	-66.0	.320	121.8	0.96	6.9	11.0

Note:

1. Gain Calculations:

$$\text{MAG} = \frac{|S_{21}|}{|S_{12}|} \left(K \pm \sqrt{K^2 - 1} \right). \text{ When } K \leq 1, \text{ MAG is undefined and MSG values are used. } \text{MSG} = \frac{|S_{21}|}{|S_{12}|}, K = \frac{1 + |\Delta|^2 - |S_{11}|^2 - |S_{22}|^2}{2 |S_{12} S_{21}|}, \Delta = S_{11} S_{22} - S_{21} S_{12}$$

MAG = Maximum Available Gain

MSG = Maximum Stable Gain

TYPICAL COMMON SOURCE SCATTERING PARAMETERS (TA = 25°C)

Vds = 2 V, Ids = 20 mA

FREQUENCY (GHz)	S11		S21		S12		S22		K	S21 (dB)	MAG ¹ (dB)
	MAG	ANG	MAG	ANG	MAG	ANG	MAG	ANG			
0.1	.999	-2.0	7.099	178.3	.002	89.3	.536	-1.2	0.05	17.0	35.5
0.2	.999	-4.3	7.053	175.9	.004	88.4	.536	-2.7	0.03	17.0	32.5
0.5	.995	-11.2	7.053	169.4	.010	83.2	.536	-7.0	0.08	17.0	28.5
1.0	.977	-22.7	6.935	158.7	.019	76.7	.532	-13.9	0.17	16.8	25.6
2.0	.919	-43.9	6.540	138.8	.037	67.0	.506	-26.3	0.31	16.3	22.5
3.0	.847	-63.8	6.026	120.3	.051	57.5	.473	-38.2	0.44	15.6	20.7
4.0	.769	-81.5	5.485	103.9	.064	48.6	.446	-47.9	0.57	14.9	19.3
5.0	.693	-97.9	4.991	89.0	.074	41.5	.412	-57.4	0.69	14.0	18.3
6.0	.625	-113.5	4.558	75.2	.082	35.3	.382	-66.2	0.80	13.2	17.4
7.0	.574	-128.4	4.181	61.9	.090	29.7	.360	-75.7	0.87	12.4	16.7
8.0	.533	-141.7	3.865	50.4	.099	24.7	.353	-83.9	0.91	11.7	15.9
9.0	.496	-153.9	3.614	38.7	.107	19.6	.347	-91.9	0.95	11.2	15.3
10.0	.455	-167.0	3.423	27.0	.116	13.8	.341	-100.7	0.98	10.7	14.7
11.0	.414	178.7	3.256	15.8	.126	8.2	.327	-109.0	1.01	10.2	13.4
12.0	.391	162.5	3.098	4.2	.133	2.2	.315	-119.4	1.03	9.8	12.6
13.0	.387	145.8	2.975	-7.1	.141	-4.6	.293	-131.7	1.03	9.5	12.1
14.0	.384	131.2	2.873	-17.9	.149	-10.8	.288	-144.0	1.02	9.2	12.0
15.0	.369	114.7	2.783	-29.9	.160	-18.3	.290	-156.5	1.01	8.9	12.0
16.0	.364	95.6	2.713	-42.0	.165	-27.1	.289	-170.3	1.01	8.7	11.6
17.0	.368	75.8	2.622	-54.7	.175	-35.5	.289	174.4	0.99	8.4	11.8
18.0	.400	59.4	2.529	-66.7	.181	-44.9	.286	158.9	0.97	8.1	11.4
19.0	.434	47.6	2.459	-78.7	.182	-55.1	.280	140.9	0.96	7.8	11.3
20.0	.468	32.4	2.386	-92.0	.185	-65.8	.275	122.3	0.95	7.5	11.1

Note:

1. Gain Calculations:

$$MAG = \frac{|S_{21}|}{|S_{12}|} (K \pm \sqrt{K^2 - 1})$$

When $K \leq 1$, MAG is undefined and MSG values are used. $MSG = \frac{|S_{21}|}{|S_{12}|}$, $K = \frac{1 + |\Delta|^2 - |S_{11}|^2 - |S_{22}|^2}{2 |S_{12} S_{21}|}$, $\Delta = S_{11} S_{22} - S_{21} S_{12}$

MAG = Maximum Available Gain

MSG = Maximum Stable Gain

OUTLINE DIMENSIONS (Units in mm)

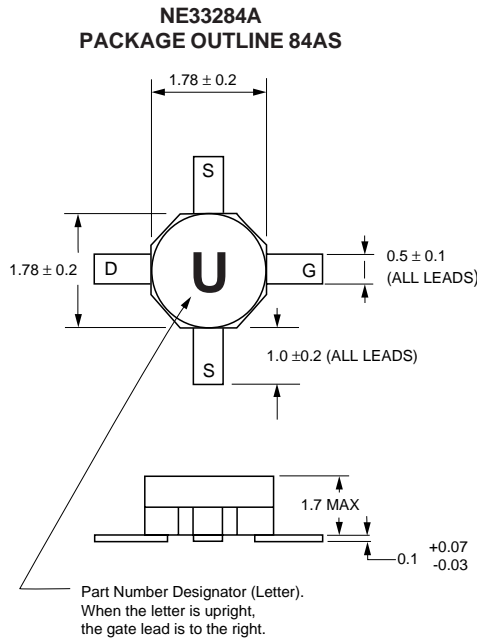

ORDERING INFORMATION¹

PART NUMBER	AVAILABILITY	PACKAGE
NE33284AS	Bulk up to 1K	84AS
NE33284A-T1	1K/Reel	84AS

Note:

Long leaded (1.7 mm min.) 84ASL package available upon request in bulk quantities up to 1000 pcs. To order specify NE33284A-SL.

NE33284A LINEAR MODEL

SCHEMATIC

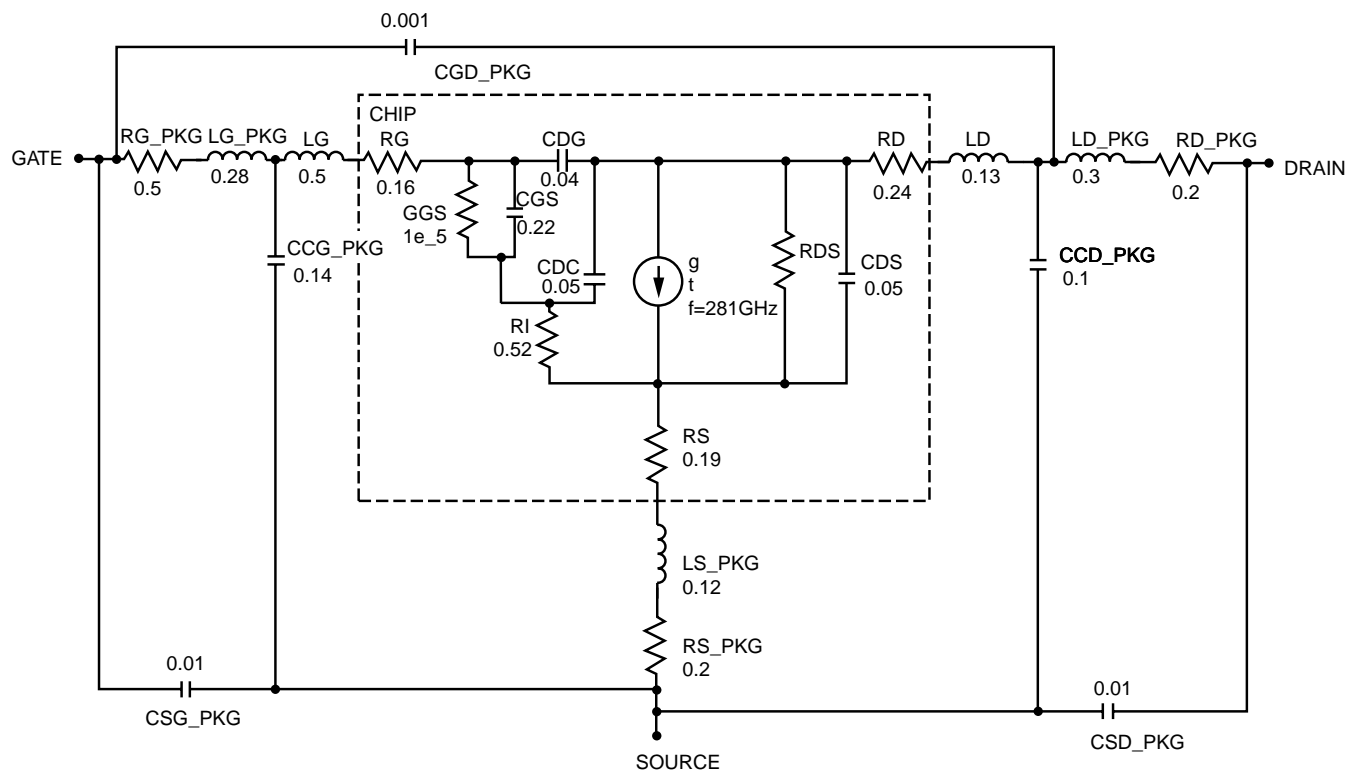

BIAS DEPENDENT MODEL PARAMETERS

Parameters	2 V, 10 mA	2 V, 20 mA	2 V, 30 mA
g	73 mS	97 mS	104 mS
t	5 pSec	5 pSec	5.5 pSec
RDS	210 ohms	156 ohms	140 ohms

UNITS

Parameter	Units
capacitance	picofarads
inductance	nanohenries
resistance	ohms
conductance	millisiemens

MODEL RANGE

Frequency: 0.1 to 20 GHz
 Bias: $V_{DS} = 2\text{ V}$, $I_D = 10, 20, 30\text{ mA}$
 Date: 7/2/96

EXCLUSIVE NORTH AMERICAN AGENT FOR **NEC** RF, MICROWAVE & OPTOELECTRONIC SEMICONDUCTORS

CEL CALIFORNIA EASTERN LABORATORIES • Headquarters • 4590 Patrick Henry Drive • Santa Clara, CA 95054-1817 • (408) 988-3500 • Telex 34-6393 • FAX (408) 988-0279
 24-Hour Fax-On-Demand: 800-390-3232 (U.S. and Canada only) • Internet: <http://WWW.CEL.COM>

DATA SUBJECT TO CHANGE WITHOUT NOTICE

PRINTED IN USA ON RECYCLED PAPER -8/98